

Colacril

ASTRA DX 140X70

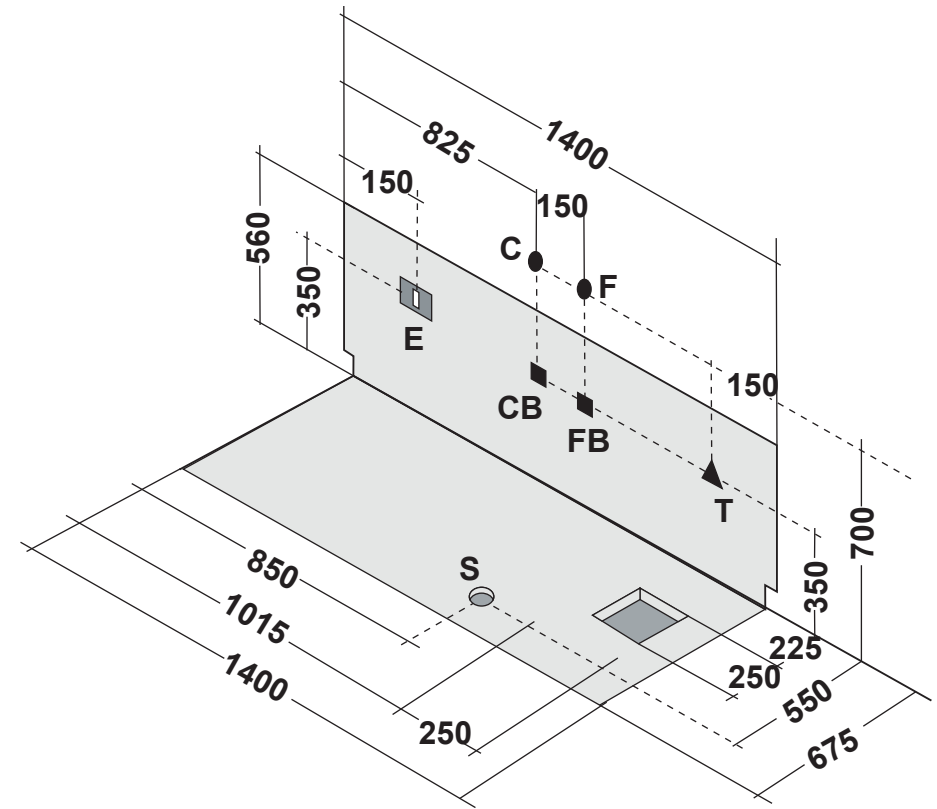
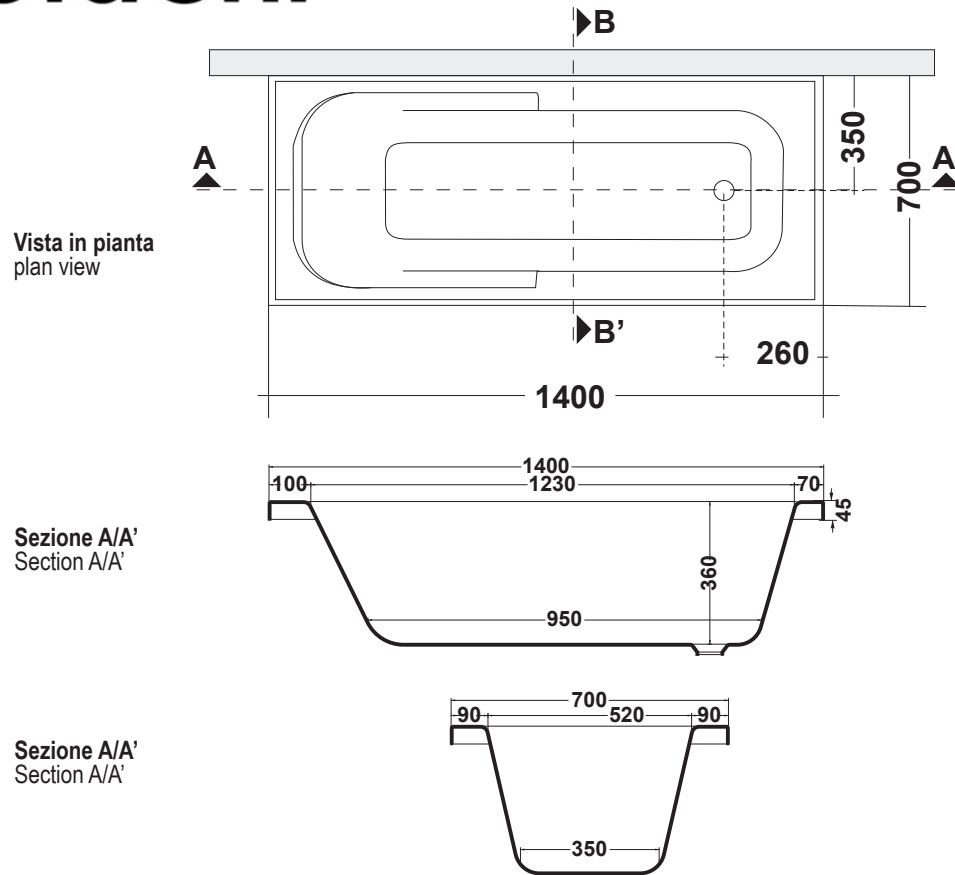

Ingombro vasca proiettato nel muro
Bath overall dimensions as projected on the wall

①	CARATTERISTICHE IDRAULICHE	CARATTERISTICHE ELETTRICHE	REQUISITI DI PREINSTALLAZIONE	COMBINAZIONI RUBINETTERIA								
<p>N.B. L'INSTALLAZIONE DEVE AVVENIRE A PAVIMENTO E PARETI FINITE</p> <p>Peso netto: Kg 45 Peso spedizione: Kg 58 Volume spedizione: m³ = 0,777 Contenuto acqua: Lt 110</p>	<p>Numero jets: 5</p>	<table border="1"> <tr> <td>V</td> <td>HZ</td> <td>KW</td> <td>A</td> </tr> <tr> <td>220/240</td> <td>50/60</td> <td>0,78</td> <td>5</td> </tr> </table>	V	HZ	KW	A	220/240	50/60	0,78	5	<p>C : Allaccio acqua calda rubinetteria parete: 1/2" F : Allaccio acqua fredda rubinetteria parete: 1/2" CB : Allaccio acqua calda bordo vasca: 1/2" FB : Allaccio acqua fredda bordo vasca: 1/2" T : Allaccio miscelatore per erogazione da troppopieno: 1/2" S : Allaccio scarico incassato a pavimento: 1-1/2" E : Allaccio elettrico idromassaggio (pressacavo PG 11): IPX5</p>	<p>C F : Rubinetteria parete ● ● CFT: Rubinetteria parete con erogazione troppopieno ● ● ● ● CB BF: Rubinetteria bordo vasca ■ ■</p>
V	HZ	KW	A									
220/240	50/60	0,78	5									
GB	WATER SYSTEM SPECIFICATION	POWER SYSTEM SPECIFICATION	CONDITION REQUIRED BEFORE THE INSTALLATION	TAPS COMBINATION								
<p>N.B. THE INSTALLATION MUST BE CARRIED OUT WITH FLOOR AND WALLS ALRESDY TILED</p> <p>Net weight: Kg 45 total weight with package: Kg 58 Volume with package: m³ = 0,777 Water capacity: Lt 110</p>	<p>Numero jets: 5</p>	<table border="1"> <tr> <td>V</td> <td>HZ</td> <td>KW</td> <td>A</td> </tr> <tr> <td>220/240</td> <td>50/60</td> <td>0,78</td> <td>5</td> </tr> </table>	V	HZ	KW	A	220/240	50/60	0,78	5	<p>C : Wall taps outlet for hot water: 1/2" F : Wall taps outlet for cold water: 1/2" CB : Bath edge taps outlet for hot water: 1/2" FB : Bath edge taps outlet for cold water: 1/2" T : Single outlet for mixed water to supply by overflowing: 1/2" S : Drainage outlet installed in the floor: 1-1/2" E : Power outlet for the whirlpool (cabling press box PG 11): IPX5</p>	<p>C F : Wall taps ● ● CFT: Wall taps with water supply by overflowing ● ● ● ● CB BF: Bath edge taps ■ ■</p>
V	HZ	KW	A									
220/240	50/60	0,78	5									