

Colacril

SHARM SX 170X70

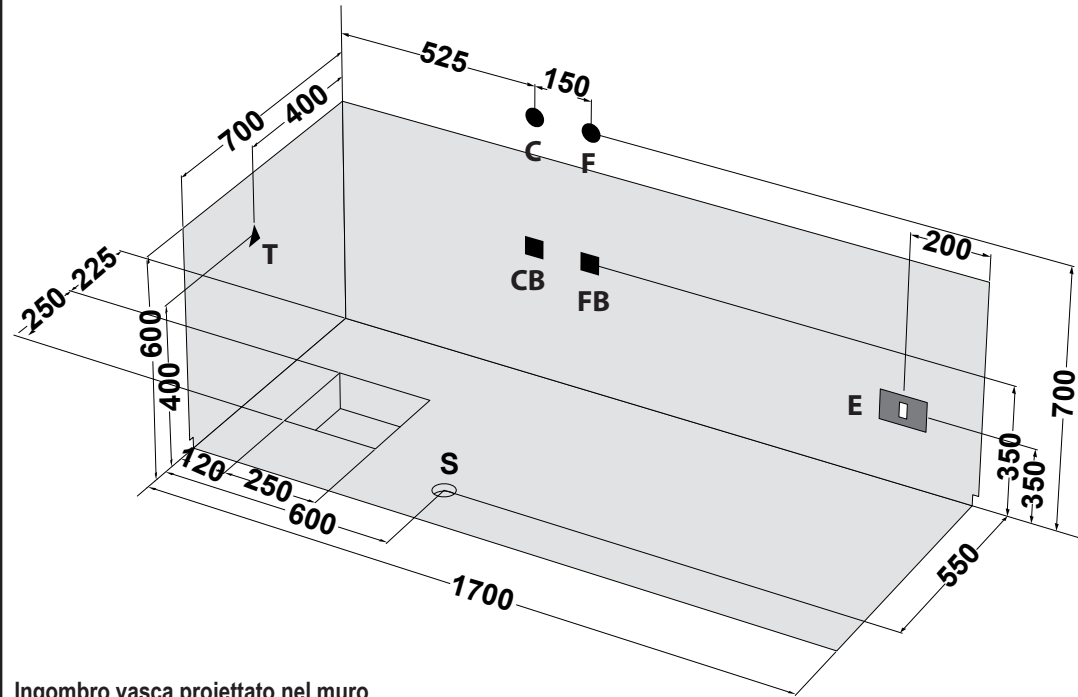
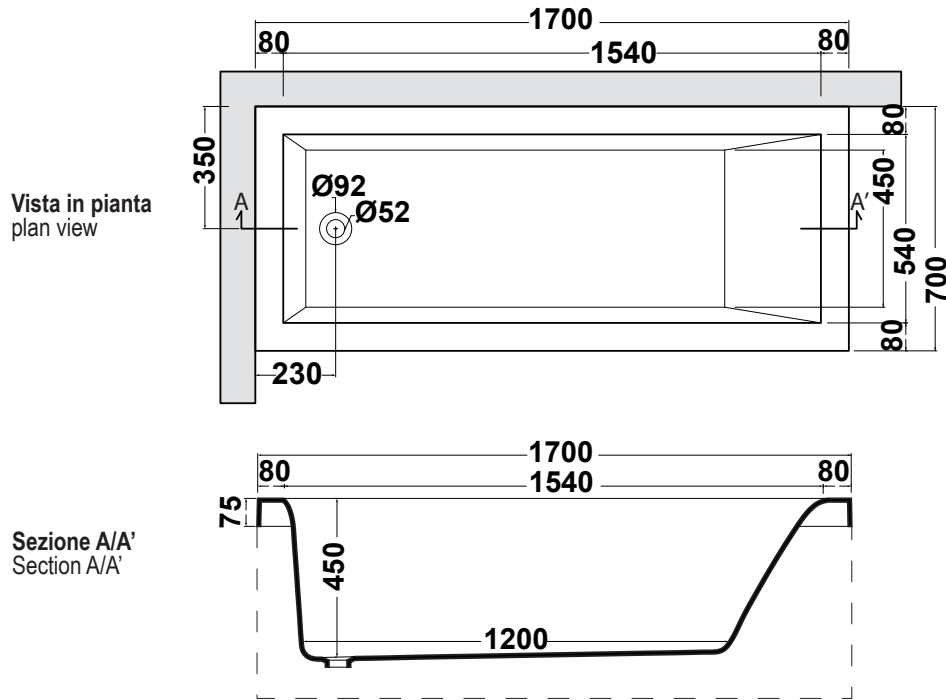

Ingombro vasca proiettato nel muro
Bath overall dimensions as projected on the wall

①	CARATTERISTICHE IDRAULICHE	CARATTERISTICHE ELETTRICHE IDROMASSAGGIO	REQUISITI DI PREINSTALLAZIONE	COMBINAZIONI RUBINETTERIA																				
<p>N.B. L'INSTALLAZIONE DEVE AVVENIRE A PAVIMENTO E PARETI FINITE</p> <p>Peso netto: Kg 58 Peso spedizione: Kg 63 Volume spedizione: m³ = 0,777 Contenuto acqua: Lt 220</p>	<p>Numero jets: 6</p> <hr/> <p>jets airpool : 12</p>	<table border="1"> <tr> <td>V</td><td>HZ</td><td>KW</td><td>A</td> </tr> <tr> <td>220/240</td><td>50/60</td><td>0,78</td><td>4,5</td> </tr> <tr> <td colspan="4">ELETTRO POMPA AIRPOOL</td> </tr> <tr> <td>V</td><td>HZ</td><td>KW</td><td>A</td> </tr> <tr> <td>220/230</td><td>50/60</td><td>0,65</td><td>3</td> </tr> </table>	V	HZ	KW	A	220/240	50/60	0,78	4,5	ELETTRO POMPA AIRPOOL				V	HZ	KW	A	220/230	50/60	0,65	3	<p>C : Allaccio acqua calda rubinetteria parete: 1/2" F : Allaccio acqua fredda rubinetteria parete: 1/2" CB : Allaccio acqua calda bordo vasca: 1/2" FB : Allaccio acqua fredda bordo vasca: 1/2" T : Allaccio miscelatore per erogazione da troppopieno: 1/2" S : Allaccio scarico incassato a pavimento: 1-1/2" E : Allaccio elettrico idromassaggio (pressacavo PG 11): IPX5</p>	<p>C F : Rubinetteria parete ● ● CFT: Rubinetteria parete con erogazione troppopieno ● ● ▲ CB FB: Rubinetteria bordo vasca ■ ■</p>
V	HZ	KW	A																					
220/240	50/60	0,78	4,5																					
ELETTRO POMPA AIRPOOL																								
V	HZ	KW	A																					
220/230	50/60	0,65	3																					
GB	WATER SYSTEM SPECIFICATION	POWER SYSTEM SPECIFICATION	CONDITION REQUIRED BEFORE THE INSTALLATION	TAPS COMBINATION																				
<p>N.B. THE INSTALLATION MUST BE CARRIED OUT WITH FLOOR AND WALLS ALRESDY TILED</p> <p>Net weight: Kg 58 total weight with package: Kg 63 Volume with package: m³ = 0,777 Water capacity: Lt 220</p>	<p>Numero jets: 6</p> <hr/> <p>jets airpool : 12</p>	<table border="1"> <tr> <td>V</td><td>HZ</td><td>KW</td><td>A</td> </tr> <tr> <td>220/240</td><td>50/60</td><td>0,78</td><td>4,5</td> </tr> <tr> <td colspan="4">ELECTRO PUMP AIRPOOL</td> </tr> <tr> <td>V</td><td>HZ</td><td>KW</td><td>A</td> </tr> <tr> <td>220/230</td><td>50/60</td><td>0,65</td><td>3</td> </tr> </table>	V	HZ	KW	A	220/240	50/60	0,78	4,5	ELECTRO PUMP AIRPOOL				V	HZ	KW	A	220/230	50/60	0,65	3	<p>C : Wall taps outlet for hot water: 1/2" F : Wall taps outlet for cold water: 1/2" CB : Bath edge taps outlet for hot water: 1/2" FB : Bath edge taps outlet for cold water: 1/2" T : Single outlet for mixed water to supply by overflowing: 1/2" S : Drainage outlet installed in the floor: 1-1/2" E : Power outlet for the wirpool (cabling press box PG 11): IPX5</p>	<p>C F : Wall taps ● ● CFT: Wall taps with water supply by overflowing ● ● ▲ CB FB: Bath edge taps ■ ■</p>
V	HZ	KW	A																					
220/240	50/60	0,78	4,5																					
ELECTRO PUMP AIRPOOL																								
V	HZ	KW	A																					
220/230	50/60	0,65	3																					