

Colacril

SHARM DX 180X80

Vista in pianta
plan view

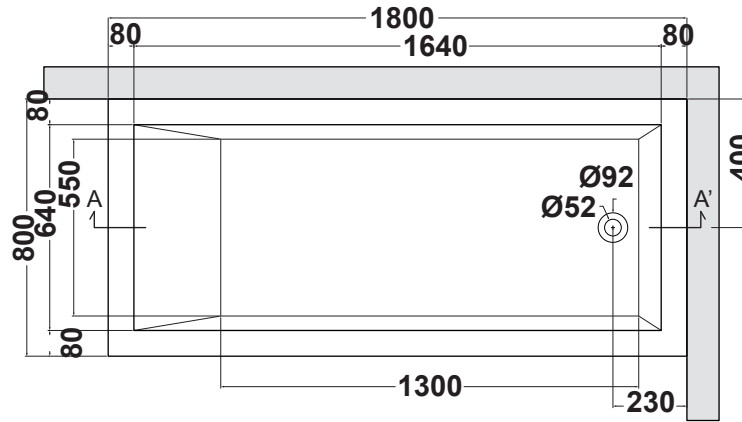

Sezione A/A'
Section A/A'

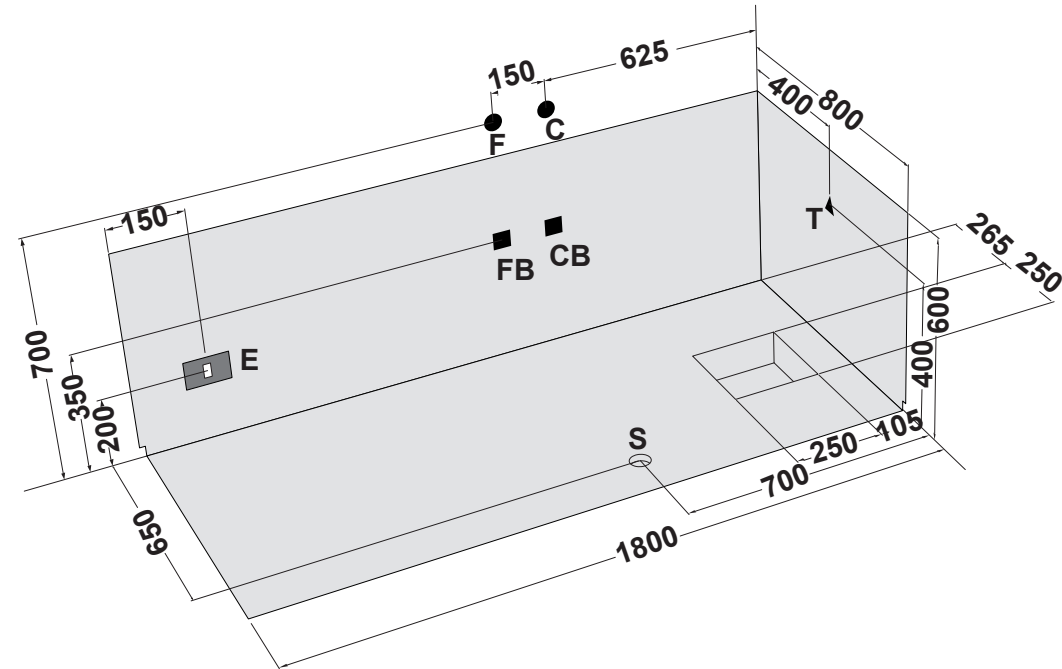
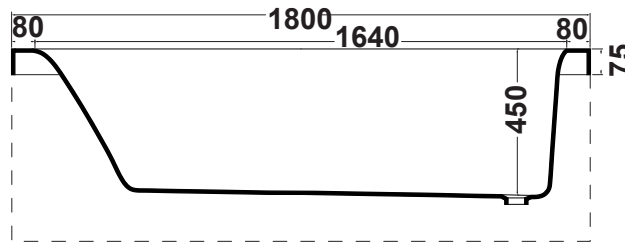

Ingombro vasca proiettato nel muro
Bath overall dimensions as projected on the wall

①	CARATTERISTICHE IDRAULICHE	CARATTERISTICHE ELETTRICHE IDROMASSAGGIO	REQUISITI DI PREINSTALLAZIONE	COMBINAZIONI RUBINETTERIA
<p>N.B. L'INSTALLAZIONE DEVE AVVENIRE A PAVIMENTO E PARETI FINITE</p> <p>Peso netto: Kg 60 Peso spedizione: Kg 65 Volume spedizione: m³ = 0,777 Contenuto acqua: Lt 260</p>	<p>Numero jets: 8</p> <hr/> <p>jets airpool : 12</p>	<p>V HZ KW A 220/240 50/60 0,78 4,5</p> <p>ELETTRO POMPA AIRPOOL</p> <p>V HZ KW A 220/230 50/60 0,65 3</p>	<p>C : Allaccio acqua calda rubinetteria parete: 1/2" F : Allaccio acqua fredda rubinetteria parete: 1/2" CB : Allaccio acqua calda bordo vasca: 1/2" FB : Allaccio acqua fredda bordo vasca: 1/2" T : Allaccio miscelatore per erogazione da troppopieno: 1/2" S : Allaccio scarico incassato a pavimento: 1-1/2" E : Allaccio elettrico idromassaggio (pressacavo PG 11): IPX5</p>	<p>C F : Rubinetteria parete ● ● CFT: Rubinetteria parete con erogazione troppopieno ● ● ▲ CB FB: Rubinetteria bordo vasca ■ ■</p>
GB	WATER SYSTEM SPECIFICATION	POWER SYSTEM SPECIFICATION	CONDITION REQUIRED BEFORE THE INSTALLATION	TAPS COMBINATION
<p>N.B. THE INSTALLATION MUST BE CARRIED OUT WITH FLOOR AND WALLS ALRESDY TILED</p> <p>Net weight: Kg 60 total weight with package: Kg 65 Volume with package: m³ = 0,777 Water capacity: Lt 260</p>	<p>Numero jets: 8</p> <hr/> <p>jets airpool : 12</p>	<p>V HZ KW A 220/240 50/60 0,78 4,5</p> <p>ELECTRO PUMP AIRPOOL</p> <p>V HZ KW A 220/230 50/60 0,65 3</p>	<p>C : Wall taps outlet for hot water: 1/2" F : Wall taps outlet for cold water: 1/2" CB : Bath edge taps outlet for hot water: 1/2" FB : Bath edge taps outlet for cold water: 1/2" T : Single outlet for mixed water to supply by overflowing: 1/2" S : Drainage outlet installed in the floor: 1-1/2" E : Power outlet for the wirpool (cabling press box PG 11): IPX5</p>	<p>C F : Wall taps ● ● CFT: Wall taps with water supply by overflowing ● ● ▲ CB FB: Bath edge taps ■ ■</p>